

Float Switches with Permanent Magnet For Vertical Installation Model RSM

WIKA Data Sheet LM 30.01



Applications

- Level measurement for almost all liquid media
- Pump/level control and monitoring for defined filling levels
- Chemical industry, petrochemical industry, natural gas, offshore, shipbuilding, machine building, power generating equipment, power stations
- Process water and drinking water treatment, food and beverage industry

Special Features

- Large scope of application due to the simple, proven functional principle
- For harsh operating conditions, long service life
- Operating limits:
 - Operating temperature: $T = -196 \dots +300 \text{ }^\circ\text{C}$
 - Working pressure: $P = \text{vacuum to } 100 \text{ bar}$
 - Limit S. G.: $\rho \geq 400 \text{ kg/m}^3$
- Wide variety of different electrical connections, process connections and materials
- Explosion-protected versions

Description

A float with a permanent magnet moves reliably along with the liquid level on a guide tube. Within the guide tube is fitted a reed contact (inert gas contact), which is energised, through the non-magnetic walls of the float and guide tube, by the approach of the float magnet. By using a magnet and reed contact the switching operation is non-contact, free from wear and needs no power supply. The contacts are potential-free. WIKA float switches with permanent magnets are also available with several switch points.



**Float Switches with Permanent Magnet,
for vertical installation, Model RSM**

**Fig. left: Stainless steel version, mounting thread
Fig. right: Plastic version, flange connection**

The switch functions always refer to a rising liquid level: normally open / normally closed / change-over contacts.

Through the use of a float for a max. of 2 switch points a bistable switch operation can be achieved, meaning that the switching status also remains available, when the filling level continues to rise above or drop below the switch point.

The float switch is simple to mount and maintenance-free, so the costs of mounting, commissioning and operation are low.

Further special features

- Process connection, guide tube material and float made of stainless steel 1.4571 or plastic
- Universal signal processing:
connection direct to a PLC is possible, NAMUR connection,
signal amplification / contact protection relays
- Works independently of foaming, conductivity, dielectricity, pressure, vacuum, temperature, steam, condensation, blistering, boiling effects and vibrations
- Multiple functionality in a single instrument - up to 8 potential-free contacts
- Exact repeatability of the switch points
- Float switches with permanent magnets qualify as passive electrical equipment in accordance with DIN IEC 60 079-11 and can be installed in 'Zone 1' hazardous areas without certification, so long as the equipment is operated in a certified intrinsically safe circuit with a minimum explosion protection of EEx ib

Options

- Customer-specific solutions
- Specific designs for interface layer detection
 $\Delta\rho \geq 50 \text{ kg / m}^3$
- Process connection, guide tube material and float made of stainless steel 1.4435, 1.4539, titanium, Hastelloy (others on request)

Application examples

Level switch (EEx i)

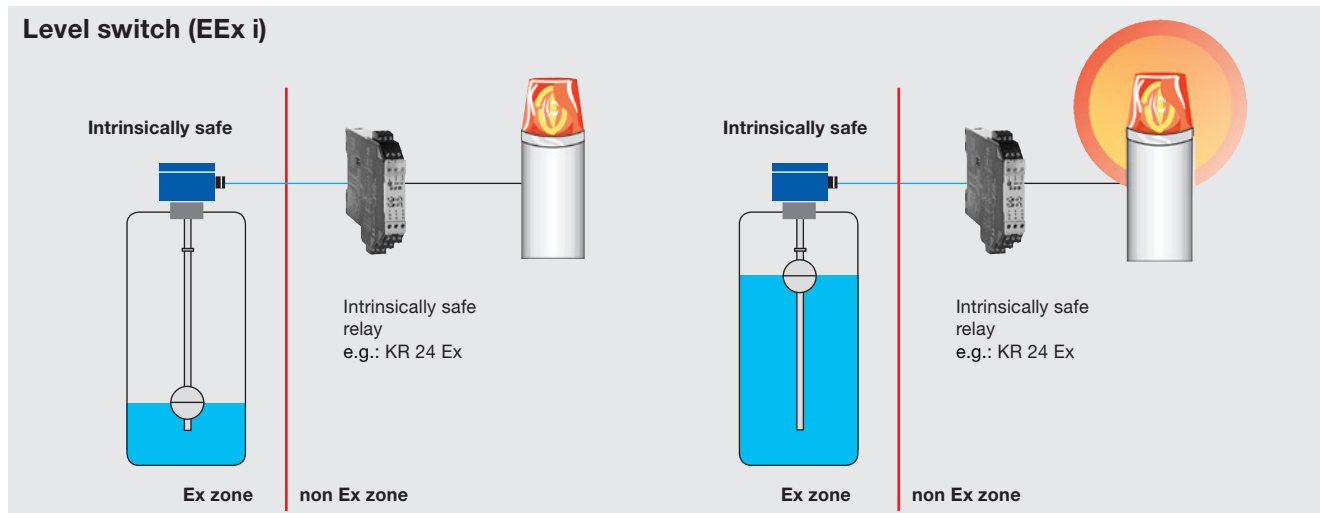

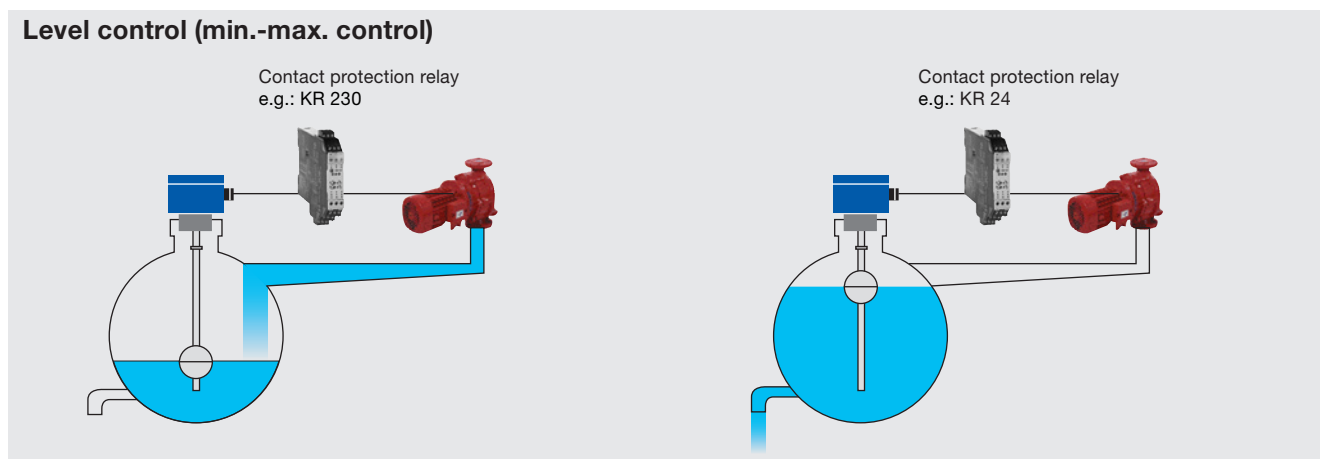

Level control (min.-max. control)



Product programme

Selection of process connection, material and design ⇒ further information on the indicated pages.

Process connection	Material Stainless steel	Explosion-protected version	Material PVC / PP / PVDF
 <p>Mounting thread (without terminal box) G 1/8" ... G 2"</p>	<p>Page 4 Page 5 (adjustable guide tube) Page 7 (Mini float)</p>	-	Page 8
 <p>Mounting thread G 1/2" ... G 2"</p>	<p>Page 4 Page 5 (adjustable guide tube) Page 7 (Mini float)</p>	Page 6	Page 8
 <p>Flange DN 50 ... DN 200 PN 6 ... PN 100</p>	<p>Page 4 Page 5 (adjustable guide tube) Page 9 (E-CTFE coated)</p>	Page 6	Page 8

Float versions: page 10 and 11

Contact protection measures: page 12

Connection diagrams: page 13 and 14

Standard version

Process connection, guide tube material and float made of stainless steel 1.4571

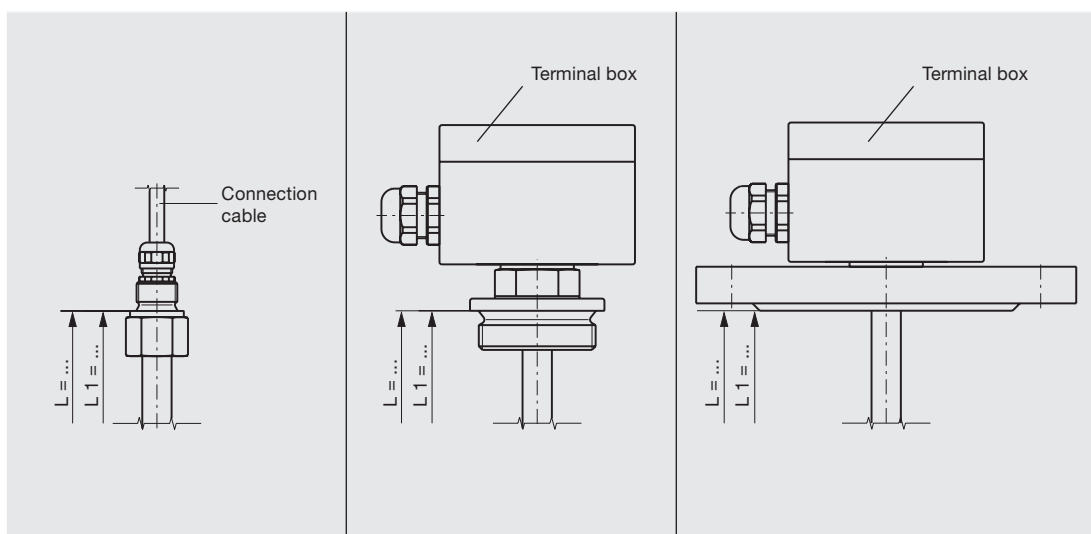

	Mounting thread (without terminal box)		Mounting thread		Flange	
Electrical connection	Connection cable ■ PVC grey ■ PVC blue ■ Silicone ■ PUR		Terminal box ■ Aluminium 64 x 58 x 34 mm, with 1 contact ■ Aluminium 80 x 75 x 57 mm, 2 or more contacts Option: Polypropylene, polyester, stainless steel			
Process connection	Mounting thread upwards G 3/8" (others on request)	G 1/2" (others on request)	Mounting thread downwards G 1 1/2" or G 2"		Mounting flange ■ DIN DN 50 ... DN 200, PN 6 ... PN 100 ■ ANSI 2" ... 8", Class 150 ... 600	
Guide tube diameter	12 or 14 mm	18 mm	12 or 14 mm	18 mm	12 or 14 mm	18 mm
Guide tube length L max.	3000 mm	6000 mm	3000 mm	6000 mm	3000 mm	6000 mm
Float	Material stainless steel 1.4571 (Option: Buna, titanium) Float diameter from 44 ... 120 mm Float selection depending on guide tube diameter and process conditions (see page 10 and 11)					
Temperature range standard	PVC / PUR cable -10 ... +80 °C Silicone cable -30 ... +150 °C		-30 ... +150 °C Option: ■ High temperature version: +150 ... +300 °C Option: ■ Low temperature version: -196 ... -30 °C			
Switch function	Optionally contact makes S, contact breaks O or change-over U - at increasing level					
Max. number of contacts	PVC cable 6 x S or O, or 4 x U Silicone cable 5 x S or O, or 3 x U		6 x S or O, or 4 x U			
Switch position	Dimensions L ₁ , L ₂ , L ₃ ... (from sealing face, starting from top)					
Distance between switch points	Minimum 20 mm (depending on the selection of the float and the contacts, see page 10 and 11)					
Contact rating	Contact makes 230 V AC; 100 VA; 1 A Contact breaks 230 V AC; 100 VA; 1 A Change-over 230 V AC; 40 VA; 1 A		230 V DC; 50 W; 0.5 A 230 V DC; 50 W; 0.5 A 230 V DC; 20 W; 0.5 A		Please observe contact protection measures (see page 12)!	
	Attention: Versions without protective earth conductor - operation only at safety extra-low voltage e.g. WIKA contact protection relay or external earthing					
Mounting position	Vertical ± 30°					
Ingress protection	IP 65 per EN 60 529 / IEC 529					

Version with adjustable guide tube

Process connection, guide tube material and float made of stainless steel 1.4571

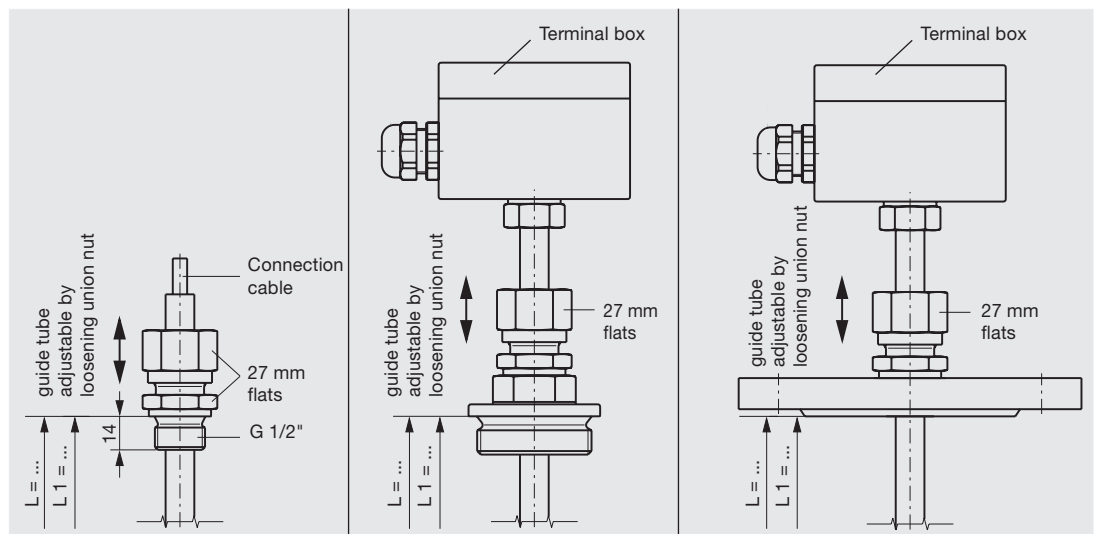

	Mounting thread (without terminal box)	Mounting thread	Flange
Electrical connection	Connection cable <ul style="list-style-type: none"> ■ PVC grey ■ PVC blue ■ Silicone ■ PUR 	Terminal box <ul style="list-style-type: none"> ■ Aluminium 64 x 58 x 34 mm, with 1 contact ■ Aluminium 80 x 75 x 57 mm, 2 or more contacts Option: Polypropylene, polyester, stainless steel 	
Process connection	Mounting thread upwards G 1/2" (others on request)	Mounting thread downwards G 1 1/2" or G 2" (others on request)	Mounting flange <ul style="list-style-type: none"> ■ DIN DN 50 ... DN 200, PN 6 ... PN 100 ■ ANSI 2" ... 8", Class 150 ... 600
Guide tube diameter	12 mm		
Guide tube length L max.	3000 mm		
Float	Material stainless steel 1.4571 (Option: Buna, titanium) Float diameter from 44 ... 83 mm Float selection depending on guide tube diameter and process conditions (see page 10 and 11)		
Nominal pressure	5 bar		
Temperature range standard	PVC / PUR cable -10 ... +80 °C Silicone cable -30 ... +150 °C	-30 ... +150 °C	
Switch function	Optionally contact makes S, contact breaks O or change-over U - at increasing level		
Max. number of contacts	PVC cable 6 x S or O, or 4 x U Silicone cable 5 x S or O, or 3 x U	6 x S or O, resp. 4 x U	
Switch position	Dimensions L ₁ , L ₂ , L ₃ ... (from sealing face, starting from top)		
Distance between switch points	Minimum 20 mm (depending on the selection of the float and the contacts, see page 10 and 11)		
Contact rating	Contact makes 230 V AC; 100 VA; 1 A Contact breaks 230 V AC; 100 VA; 1 A Change-over 230 V AC; 40 VA; 1 A	230 V DC; 50 W; 0.5 A 230 V DC; 50 W; 0.5 A 230 V DC; 20 W; 0.5 A	
	Please observe contact protection measures (see page 12)!		
	Attention: Versions without protective earth conductor - operation only at safety extra-low voltage e.g. WIKA contact protection relay or external earthing		
Mounting position	Vertical ± 30°		
Ingress protection	IP 54 per EN 60 529 / IEC 529	IP 65 per EN 60 529 / IEC 529	

Explosion-protected version, intrinsically safe

II 1/2G EEx ia IIC T3-T6 KEMA 09 ATEX 0182X

II 2D T80 °C IP6X

Process connection, guide tube material and float made of stainless steel 1.4571

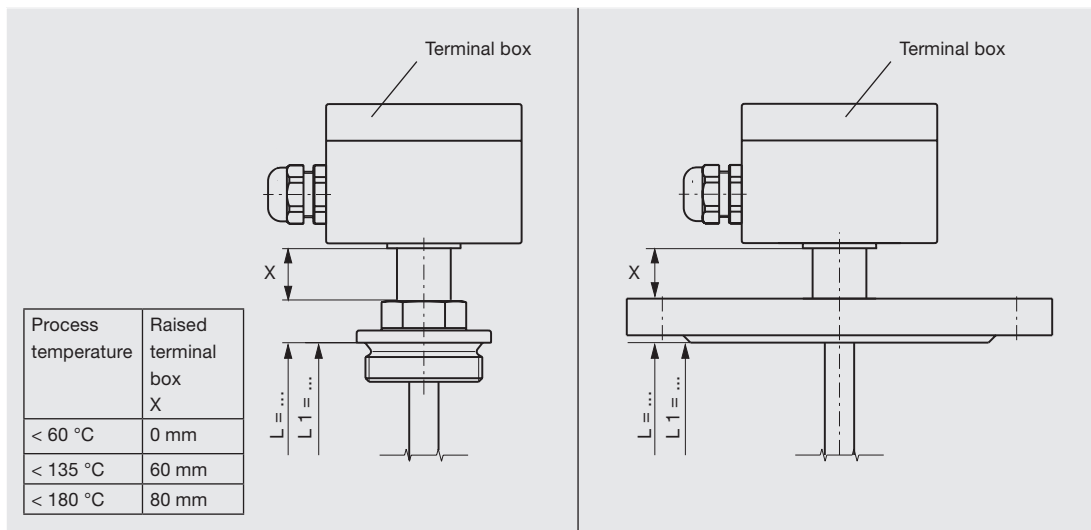

Mounting thread		Flange		
Electrical connection	Terminal box ■ Aluminium 80 x 75 x 57 mm Option: Polyester, stainless steel			
Process connection	Mounting thread downwards G 1 1/2" or G 2" (others on request)	Mounting flange ■ DIN DN 50 ... DN 150, PN 6 ... PN 64 ■ ANSI 2" ... 6", Class 150 ... 600		
Guide tube diameter	12 or 14 mm 18 mm	12 or 14 mm	18 mm	
Guide tube length L max.	3000 mm 6000 mm	3000 mm	6000 mm	
Float	Material stainless steel 1.4571 (Option: Buna, titanium) Float diameter from 44 ... 120 mm Float selection depending on guide tube diameter and process conditions (see page 10 and 11)			
Temperature class	T3	T4	T5	T6
Process temperature	Max. 180 °C	130 °C	95 °C	80 °C
Ambient temperature at terminal box	Max. 60 °C	60 °C	60 °C	60 °C
Switch function	Optionally contact makes S, contact breaks O or change-over U - at increasing level			
Max. number of contacts	6 x S or O, or 4 x U			
Switch position	Dimensions L ₁ , L ₂ , L ₃ ... (from sealing face, starting from top)			
Distance between switch points	Minimum 20 mm (depending on the selection of the float and the contacts, see page 10 and 11)			
Contact rating	Only for connection to a certified intrinsically safe circuit with U _{max} 36 V, I _{max} 100 mA			
Mounting position	Vertical ± 30°			
Ingress protection	IP 65 per EN 60 529 / IEC 529			
Options	<ul style="list-style-type: none"> ■ Temperature resistance Pt100 or Pt1000 ■ Bimetal thermal contact 40 ... 120 °C (in 5 degree steps) 			

Mini float version

Process connection and guide tube material made of stainless steel 1.4571

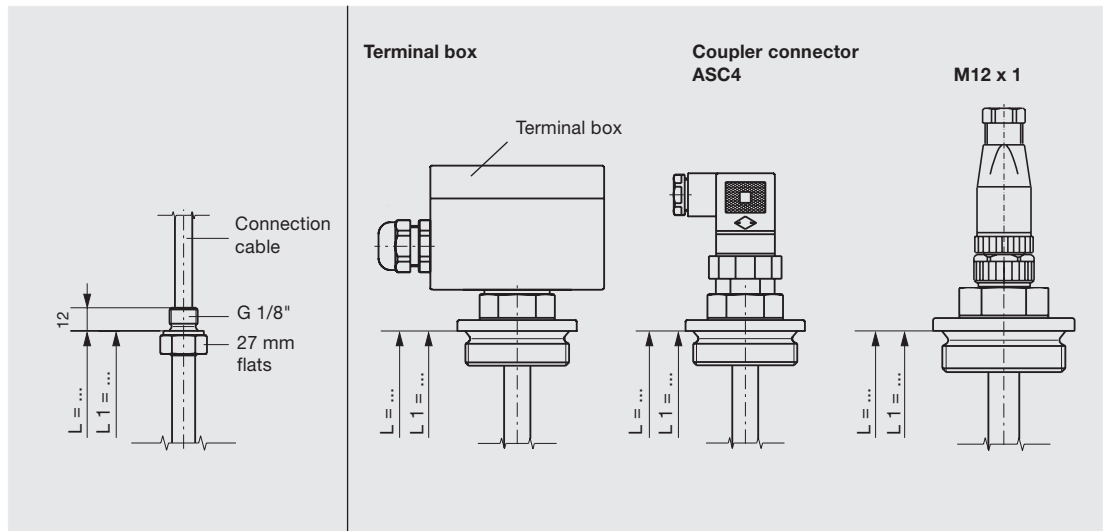

Mounting thread (without terminal box)		Mounting thread													
Electrical connection	Connection cable <ul style="list-style-type: none"> ■ PVC grey ■ PVC blue ■ Silicone ■ PUR 	Terminal box <ul style="list-style-type: none"> ■ Aluminium 64 x 58 x 34 mm 	Coupler connector <ul style="list-style-type: none"> ■ ASC4, C 164-232-F-4P 	Coupler connector <ul style="list-style-type: none"> ■ M12 x 1 											
Process connection	Mounting thread upwards G 1/8" (others on request)	Mounting thread downwards oder G 1" (others on request)													
Guide tube diameter	8 mm														
Guide tube length L max.	500 mm														
Float	Material stainless steel 1.4571 (Option: Buna, polypropylene, titanium) Float diameter from 23 ... 29 mm Float selection depending on guide tube diameter and process conditions (see page 10 and 11)														
Temperature range	-10 ... +100 °C (Float material stainless steel or titanium) -10 ... +80 °C (Float material Buna or polypropylene)														
Switch function	Optionally contact makes S, contact breaks O or change over U - at increasing level														
Max. number of contacts	3 x S or O, or 1 x U														
Contact rating	<table border="0" style="width: 100%;"> <tr> <td style="width: 25%;">Contact makes</td> <td style="width: 25%;">250 V AC; 10 VA; 0.5 A</td> <td style="width: 25%;">250 V DC; 5 W; 0.25 A</td> <td style="width: 25%;"></td> </tr> <tr> <td>Contact breaks</td> <td>250 V AC; 10 VA; 0.5 A</td> <td>250 V DC; 5 W; 0.25 A</td> <td rowspan="2" style="text-align: right; vertical-align: top;">Please observe contact protection measures (see page 12)!</td> </tr> <tr> <td>Change-over</td> <td>28 V AC; 6 VA; 0.6 A</td> <td>28 V DC; 3 W; 0.3 A</td> </tr> </table>				Contact makes	250 V AC; 10 VA; 0.5 A	250 V DC; 5 W; 0.25 A		Contact breaks	250 V AC; 10 VA; 0.5 A	250 V DC; 5 W; 0.25 A	Please observe contact protection measures (see page 12)!	Change-over	28 V AC; 6 VA; 0.6 A	28 V DC; 3 W; 0.3 A
Contact makes	250 V AC; 10 VA; 0.5 A	250 V DC; 5 W; 0.25 A													
Contact breaks	250 V AC; 10 VA; 0.5 A	250 V DC; 5 W; 0.25 A	Please observe contact protection measures (see page 12)!												
Change-over	28 V AC; 6 VA; 0.6 A	28 V DC; 3 W; 0.3 A													
Attention: Versions without protective earth conductor - operation only at safety extra-low voltage e.g. WIKA contact protection relay or external earthing															
Mounting position	Vertical ± 30°														
Ingress protection	IP 54 per EN 60 529 / IEC 529		IP 65 per EN 60 529 / IEC 529												

Plastic version

Process connection, guide tube material and float made of PVC, polypropylene or PVDF

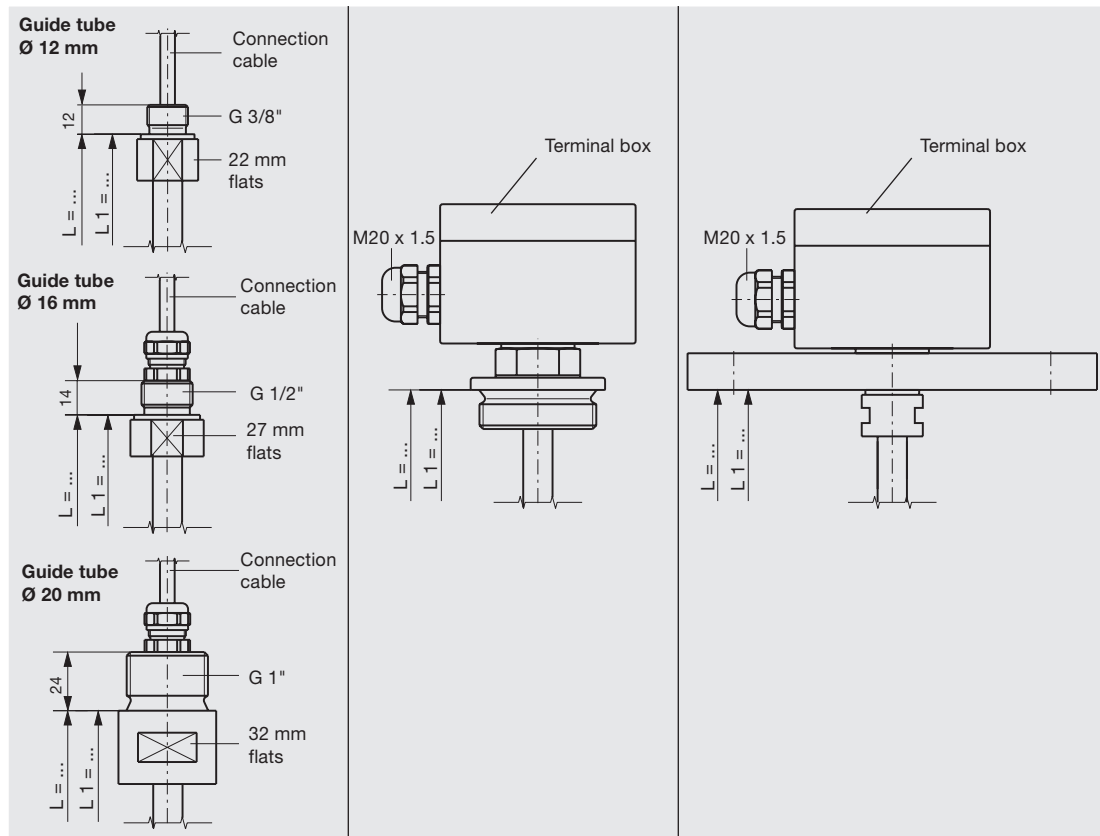

	Mounting thread (without terminal box)	Mounting thread	Flange
Electrical connection	Connection cable <ul style="list-style-type: none"> ■ PVC grey ■ PVC blue ■ PUR 	Terminal box <ul style="list-style-type: none"> ■ Polypropylene 80 x 82 x 55 mm 	
Process connection	Mounting thread, upwards <ul style="list-style-type: none"> ■ G 3/8" (Guide tube Ø 12 mm) ■ G 1/2" (Guide tube Ø 16 mm) ■ G 1" (Guide tube Ø 20 mm) (others on request)	Mounting thread, downwards <ul style="list-style-type: none"> G 1 1/2" or G 2" (others on request) 	Mounting flange <ul style="list-style-type: none"> ■ DIN DN 50 ... DN 125, PN 10, Form A ■ ANSI 2" ... 5", Class 150 FF
Guide tube diameter	12, 16 or 20 mm (16 and 20 mm: strengthened with a metallic inner tube)		
Guide tube length L max.	<ul style="list-style-type: none"> ■ 500 mm (Guide tube Ø 12 mm) ■ 3000 mm (Guide tube Ø 16 mm) ■ 5000 mm (Guide tube Ø 20 mm) 		
Float	Material <ul style="list-style-type: none"> ■ PVC ■ Polypropylene ■ PVDF Float diameter from 44 ... 80 mm Float selection depending on guide tube diameter and process conditions (see page 11)		
Temperature range	<ul style="list-style-type: none"> ■ PVC 0 ... +60 °C ■ Polypropylene -10 ... +80 °C ■ PVDF -10 ... +100 °C 		
Switch function	Optionally contact makes S, contact breaks O or change-over U - at increasing level		
Max. number of contacts	4 x S or O (PP max. 3) resp. 3 x U (PP max. 2)		
Switch position	Dimensions L ₁ , L ₂ , L ₃ ... (from sealing face, starting from top)		
Distance between switch points	Minimum 20 mm (depending on the selection of the float and the contacts, see page 11)		
Contact rating	Contact makes 230 V AC; 100 VA; 1 A 230 V DC; 50 W; 0.5 A Contact breaks 230 V AC; 100 VA; 1 A 230 V DC; 50 W; 0.5 A Please observe contact protection measures (see page 12)! Change-over 230 V AC; 40 VA; 1 A 230 V DC; 20 W; 0.5 A		
	Attention: Versions without protective earth conductor - operation only at safety extra-low voltage e.g. WIKA contact protection relay or external earthing		
Mounting position	Vertical ± 30°		
Ingress protection	IP 54 per EN 60 529 / IEC 529	IP 65 per EN 60 529 / IEC 529	

Stainless steel version, E-CTFE coated

Process connection, guide tube material and float made of stainless steel 1.4571, E-CTFE coated

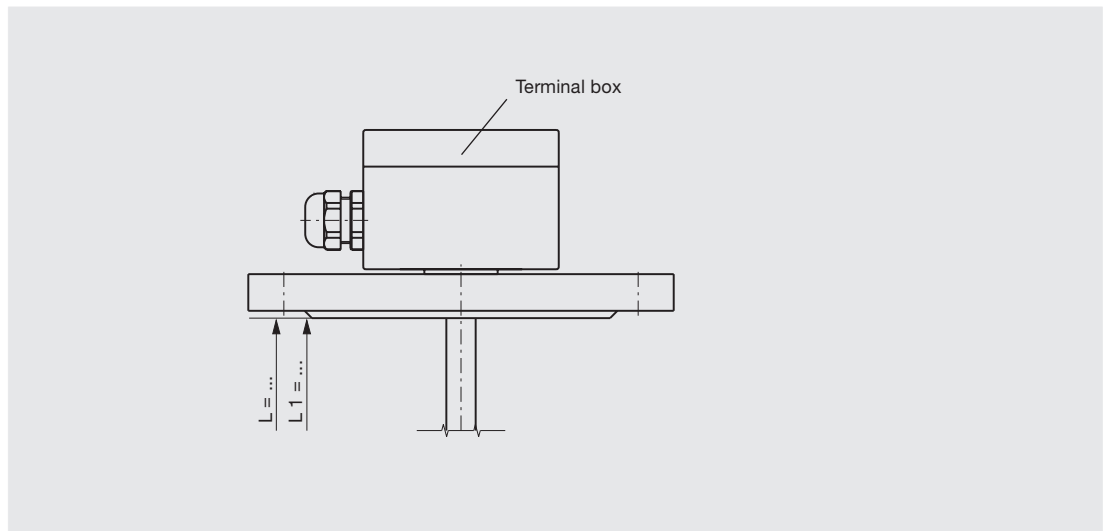

	Flange (Guide tube diameter 12 mm)	Flange (Guide tube diameter 18 mm)										
Electrical connection	Terminal box <ul style="list-style-type: none"> ■ Aluminium 64 x 58 x 34 mm, with 1 contact ■ Aluminium 80 x 75 x 57 mm, 2 or more contacts Option: Polypropylene, polyester, stainless steel 											
Process connections	Mounting flange <ul style="list-style-type: none"> ■ DIN DN 50 ... DN 200, PN 6 ... PN 40 ■ ANSI 2" ... 8", Class 150 ... 300 											
Guide tube diameter	12 mm	18 mm										
Guide tube length L max.	2000 mm	4000 mm										
Float	Material stainless steel 1.4571 (E-CTFE coated) Float diameter from 45 ... 121 mm Float selection depending on guide tube diameter and process conditions (see page 10)											
Temperature range	Depending on medium											
Switch function	Optionally contact makes S, contact breaks O or change-over U - at increasing level											
Max. number of contacts	3 x S or O, resp. 2 x U											
Switch position	Dimensions L ₁ , L ₂ , L ₃ ... (from sealing face, starting from top)											
Distance between switch points	Minimum 20 mm (depending on the selection of the float and the contacts, see page 10)											
Contact rating	<table border="0" style="width: 100%;"> <tr> <td>Contact makes</td> <td>230 V AC; 100 VA; 1 A</td> <td>230 V DC; 50 W; 0.5 A</td> <td rowspan="3" style="vertical-align: middle;">Please observe contact protection measures (see page 12)!</td> </tr> <tr> <td>Contact breaks</td> <td>230 V AC; 100 VA; 1 A</td> <td>230 V DC; 50 W; 0.5 A</td> </tr> <tr> <td>Change-over</td> <td>230 V AC; 40 VA; 1 A</td> <td>230 V DC; 20 W; 0.5 A</td> </tr> </table> <p>Attention: Versions without protective earth conductor - operation only at safety extra-low voltage e.g. WIKA contact protection relay or external earthing</p>		Contact makes	230 V AC; 100 VA; 1 A	230 V DC; 50 W; 0.5 A	Please observe contact protection measures (see page 12)!	Contact breaks	230 V AC; 100 VA; 1 A	230 V DC; 50 W; 0.5 A	Change-over	230 V AC; 40 VA; 1 A	230 V DC; 20 W; 0.5 A
Contact makes	230 V AC; 100 VA; 1 A	230 V DC; 50 W; 0.5 A	Please observe contact protection measures (see page 12)!									
Contact breaks	230 V AC; 100 VA; 1 A	230 V DC; 50 W; 0.5 A										
Change-over	230 V AC; 40 VA; 1 A	230 V DC; 20 W; 0.5 A										
Mounting position	Vertical ± 30°											
Ingress protection	IP 65 per EN 60 529 / IEC 529											

Spherical floats (K)

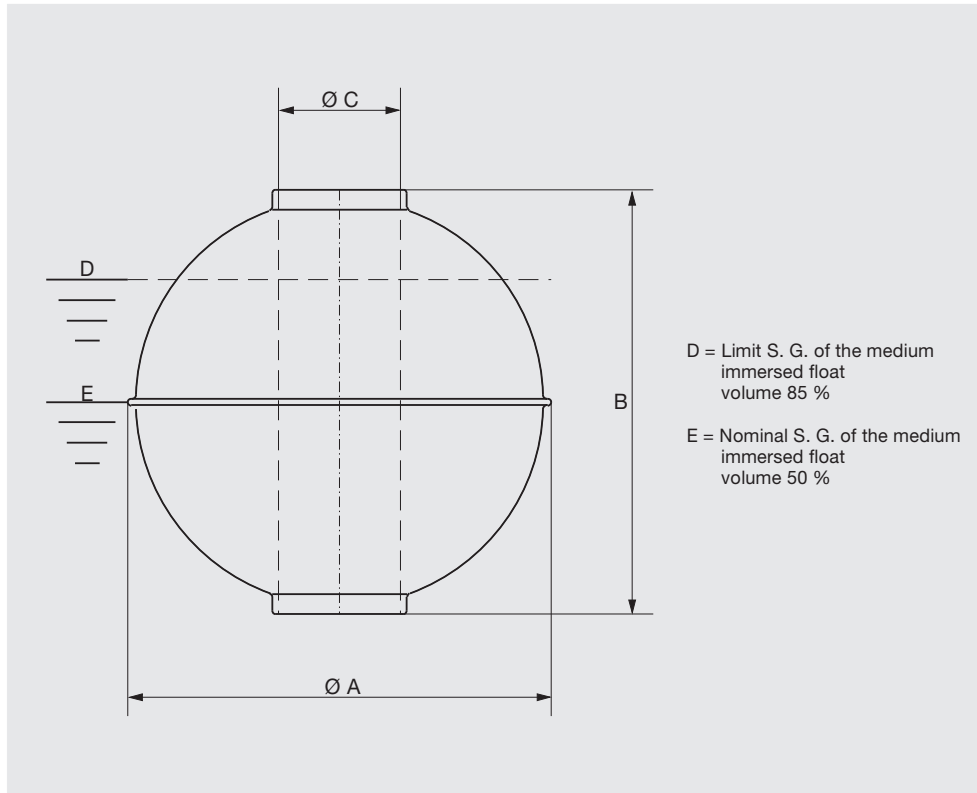

Material	Suits guide tube Ø mm	Ø A mm	B mm	Ø C mm	Max. working pressure bar	Max. operating temperature °C	Limit S. G. 85 % kg/m ³	Nominal S. G. 50 % kg/m ³
Stainless steel 1.4571	8	29	28	9	6	100	977	1660
	8	29	28	9	25	100	1069	1817
	12	52	52	15	40	300	769	1307
	12	62	61	15	32	300	597	1015
	12	83	81	15	25	300	408	693
	18	80	76	23	25	300	679	1155
	18	98	96	23	25	300	597	1016
	18	105	103	23	25	300	533	907
	18	120	117	23	25	300	389	661
Titanium 3.7035	8	29	28	9	30	100	822	1397
	12	52	52	15	25	300	707	1201
	12	52	52	15	60	300	852	1448
	12	52	52	15	80	300	1060	1802
	12	62	62	15	25	300	505	859
	12	83	81	15	25	300	278	473
	18	80	76	23	25	300	665	1130
	18	98	96	23	25	300	495	841
	18	105	103	23	25	300	369	627
	18	120	117	23	25	300	329	560
Stainless steel 1.4571 E-CTFE coated	12	53	53	14	25	depending on medium	745	1266
	12	63	62	14	25	depending on medium	591	1005
	12	84	82	14	25	depending on medium	403	685
	18	81	77	22	25	depending on medium	718	1220
	18	99	97	22	25	depending on medium	675	1148
	18	106	104	22	25	depending on medium	633	1076
	18	121	118	22	25	depending on medium	459	781

Note: The optimum float will be selected after a feasibility test carried out by WIKA.

Cylindrical floats (Z)

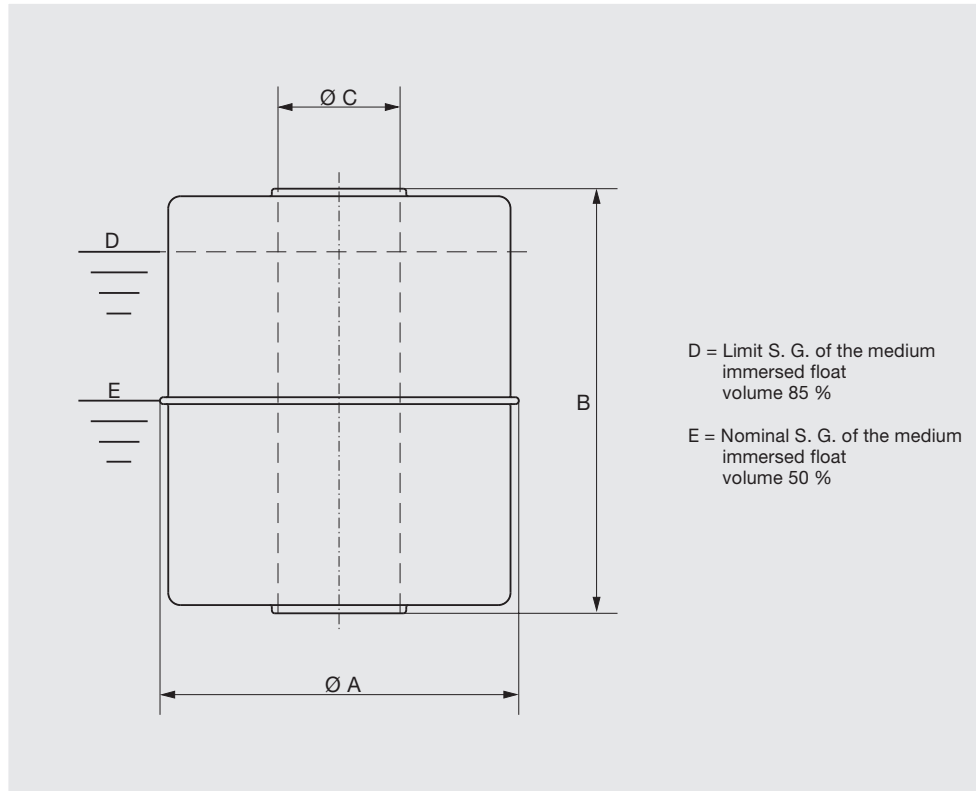

Material	Suits guide tube \varnothing mm	$\varnothing A$ mm	B mm	$\varnothing C$ mm	Max. working pressure bar	Max. operating temperature $^{\circ}C$	Limit S. G. 85 % kg/m^3	Nominal S. G. 50 % kg/m^3
Stainless steel 1.4571	8	27	31	10	16	100	787	1338
	12	44	52	15	16	300	818	1390
Titanium 3.7035	12	44	52	15	16	300	720	1224
Buna	8	20	20	9	3	80	939	1597
	8	23	25	9	3	80	802	1364
	8	25	14	9	3	80	787	1337
	8	30	45	13	3	80	683	1161
	12	40	30	15	3	80	581	988
	12	40	120	15	3	80	409	694
	18	50	45	19	3	80	498	847
PVC	12	44	44	14	3	60	651	1107
	16	55	54	22	3	60	798	1357
	20	55	80	26	3	60	919	1563
	16	55	70	22	3	60	674	1145
	20	80	79	25	3	60	573	974
Polypropylene	8	27	29	9	3	80	755	1284
	8	35	33	9	3	80	675	1148
	12	44	44	14	3	80	478	812
	16	55	54	22	3	80	582	989
	20	55	80	26	3	80	669	1137
	20	80	79	25	3	80	431	732
PVDF	12	44	55	14	3	100	782	1329
	16	55	69	22	3	100	821	1396
	20	55	80	26	3	100	1140	1938
	20	80	79	25	3	100	681	1157
Stainless steel 1.4571 E-CTFE coated	12	45	53	14	16	depending on medium	782	1329

Note: The optimum float will be selected after a feasibility test carried out by WIKA.

Contact protection measures

To ensure reliable operation of sensors with reed switches and highest possible service life, we recommend using one of the following circuits.

Inductive load AC

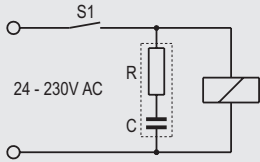

RC modules depending on operating voltage see table

Surge current measurement with oscilloscope

Example:
C = 0.33 μ F/24 V DC

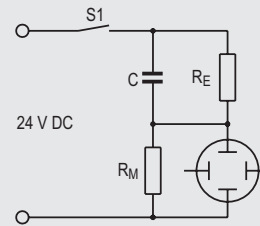

Inductive load DC

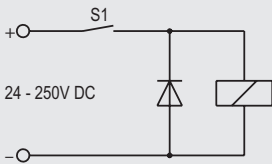

Shunt diode
e.g. 1N4007

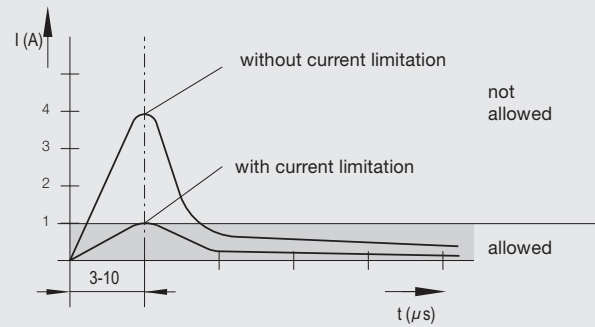

Protective RC modules

RC modules are, depending on the operating voltage, to be used exclusively according to the table below.

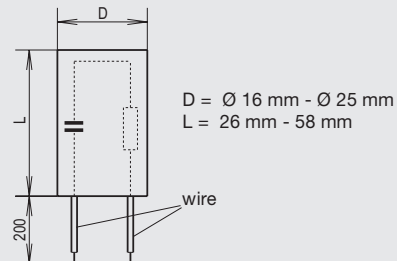

Current limitation with capacitive load e.g. PLC, DCS and cables > 50 m

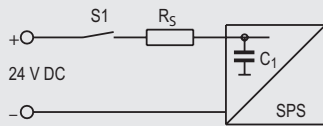

$R_S = 22 \text{ Ohm}$
(47 Ohm with 0 VA contacts)
 $C_1 =$ internal capacitance

Current limitation with electronic timers

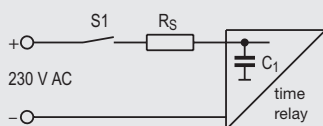

$R_S = 220 \text{ Ohm}$
(230 V AC)
 $C_1 =$ internal capacitance

For inert gas contacts from 10 ... 40 VA

Capacitance	Resistance	Voltage
0.33 μ F	100 Ohm	24 V AC
0.33 μ F	220 Ohm	48 V AC
0.33 μ F	470 Ohm	115 V AC
0.33 μ F	1500 Ohm	230 V AC

For inert gas contacts from 40 ... 100 VA

Capacitance	Resistance	Voltage
0.33 μ F	47 Ohm	24 V AC
0.33 μ F	100 Ohm	48 V AC
0.33 μ F	470 Ohm	115 V AC
0.33 μ F	1000 Ohm	230 V AC

Other types than the RC modules specified here might lead to destruction of the reed contact.

Connection diagrams

Colour coding per IEC 757

PVC cable

Contact makes or breaks

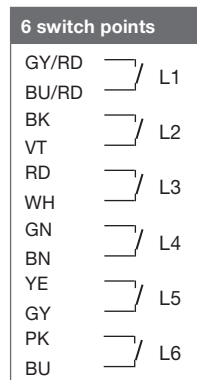
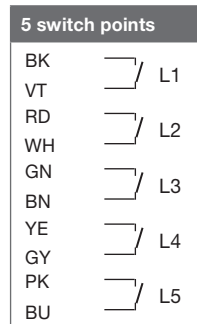
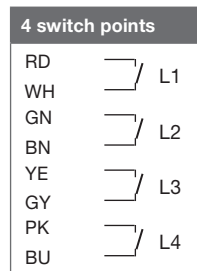
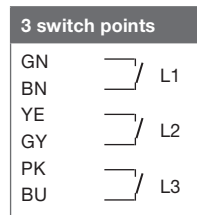
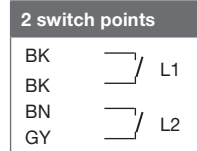
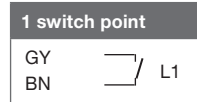

Change-over

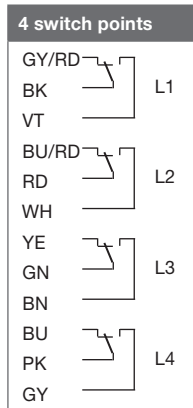
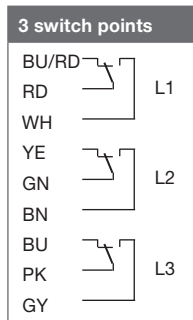
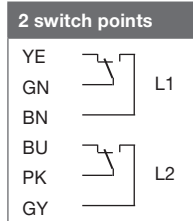
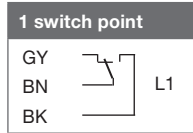

Silicone cable

Contact makes or breaks

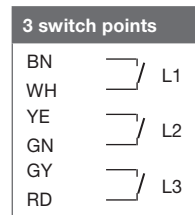
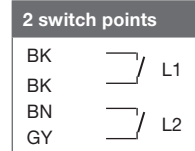
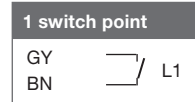

Change-over

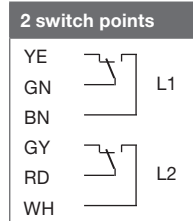
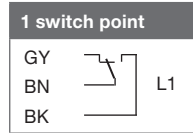

Terminal box

Contact makes or breaks

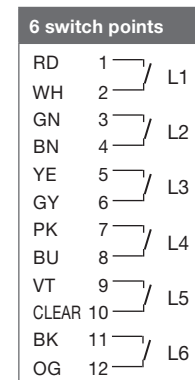
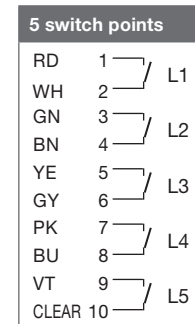
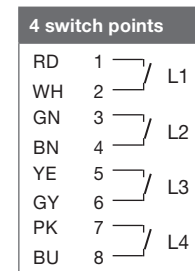
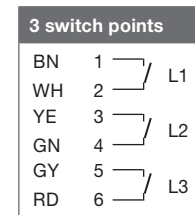
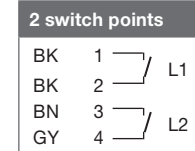
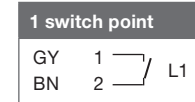

Change-over

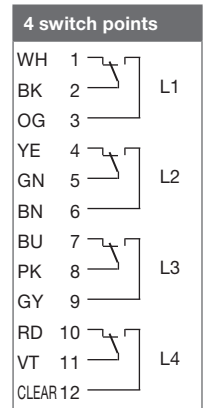
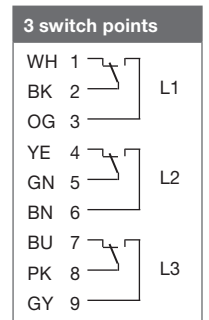
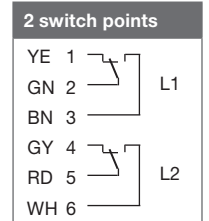
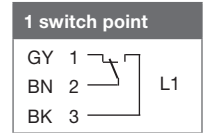

Connection diagrams

Colour coding per IEC 757

Coupler connector ASC4

Contact makes or breaks

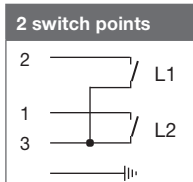
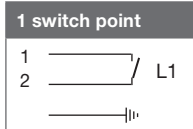

Change-over or breaks

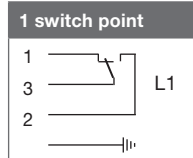

Coupler connector M12

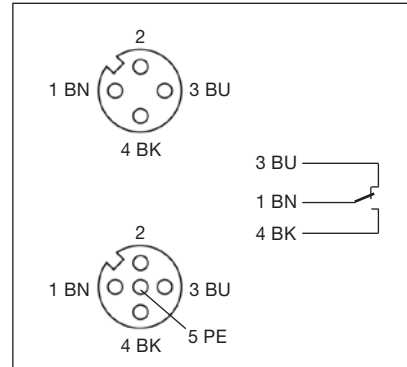

Float switches with thermal contacts

PVC or silicone cable or terminal box

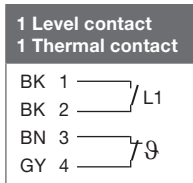

PVC cable

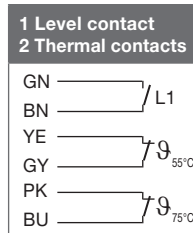

Silicone cable or terminal box

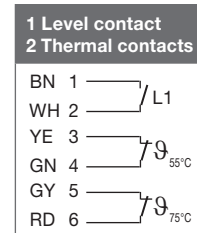

PVC or silicone cable or terminal box

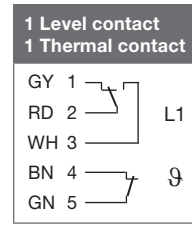

PVC cable

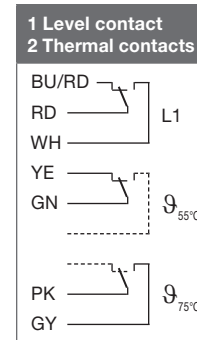

Terminal box

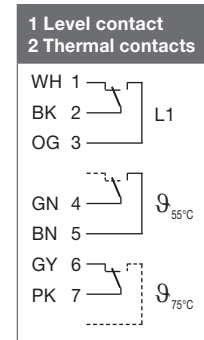

Coupler connector ASC4

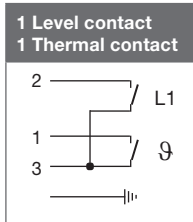

Coupler connector M12

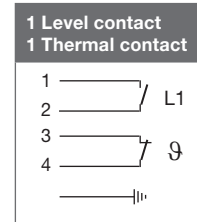

Coupler connector M12

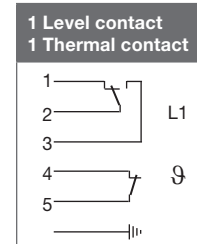

Ordering information

Model / Version / Electrical connection / Process connection / Guide tube diameter / Guide tube length L / Information about contact (switch function, number of switch points, switch position) / Process details (operating temperature and pressure, Limit S. G.) / Options

Modifications may take place and materials specified may be replaced by others without prior notice. Specifications and dimensions given in this leaflet represent the state of engineering at the time of printing.

