

02V

01/04

Thermostatic Control Valve

B Valve

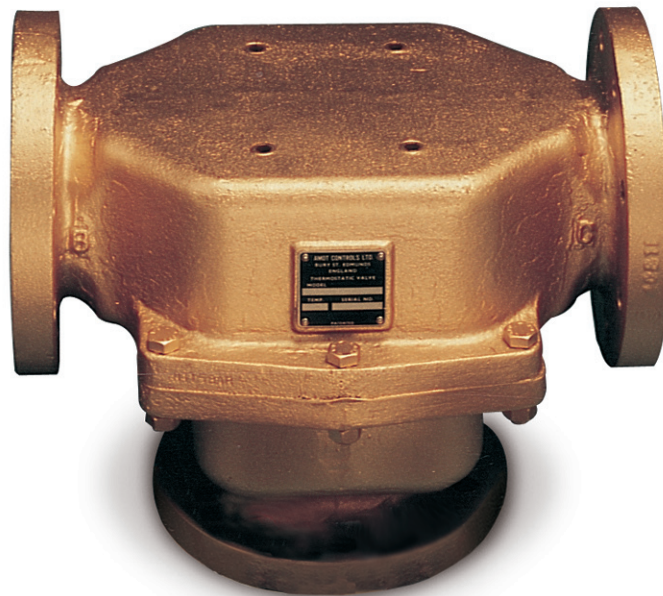

Recommended applications

- Lubricating oil temperature control
- Jacket water high temperature (HT)
- Secondary water low temperature (LT)
- Heat recovery
- Water saving applications
- Boiler inlet temperature control
- Co-generation, cooling towers

Key benefits

- No external power source required - simple, low cost installation
- No user setting needed - 'fit and forget' solution
- Small number of parts - simple maintenance and low cost of ownership
- Robust design capable of high vibration and shock applications

Operation

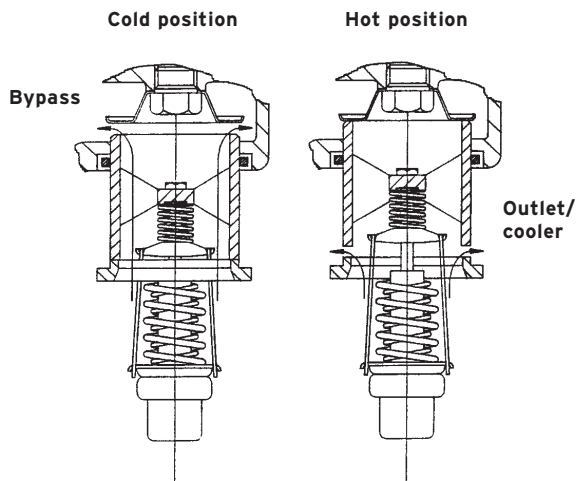

Note: Typical for sliding valve type elements

The temperature control power is created by the expansion of a wax/copper mixture which is highly sensitive to temperature changes.

Large forces are created by the warming/ expansion of the mixture which in turn acts upon the sliding valve, thus regulating the flow.

The diagram opposite shows the valve actuation in diverting mode at start and cooling positions.

During operation the sliding valve constantly modulates for accurate temperature control.

The reliable rugged construction provides a unit sensitive to temperature variations, not easily disturbed by pressure changes and sudden surges and maintains stable temperatures over a wide range of operating conditions.

Applications

Diverting applications

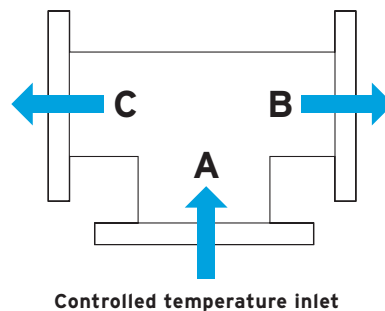
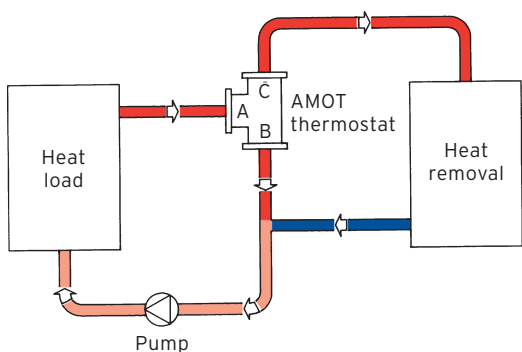

Mixing applications

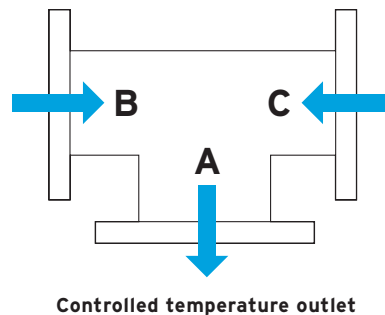
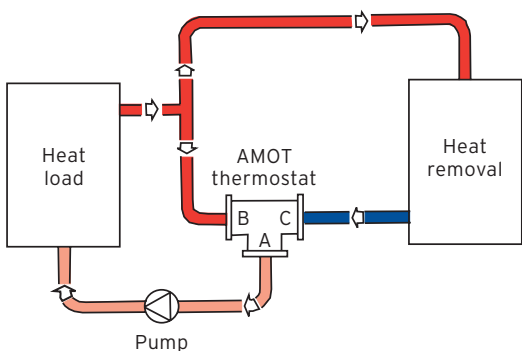

Boiler return applications

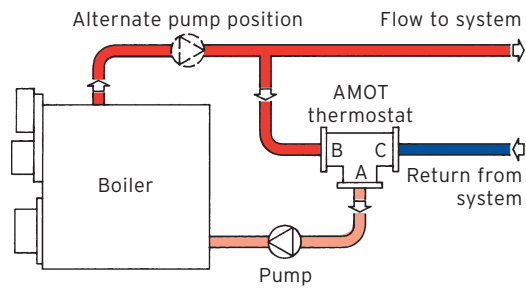

Water saving applications

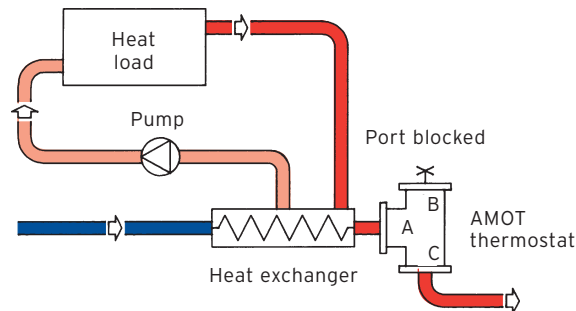

Valve as shown maintains minimum flow through cooler to conserve water, requires internal leak hole to permit small flow for sensing.

Specification

Flow rate	10 - 450m ³ /hr	
Body materials	Aluminium (BS: 1490 LM25TF)	For light weight
	Bronze (BS: 1400 LG2)	For seawater, shock resistance and low magnetic permeability
	Cast iron (BS: 1452 250)	For fresh water and lubricating oils
	Ductile iron (BS: 2789 420/12)	High performance iron
	Steel (BS: 3100 A1)	For high strength/pressure ratings
	Stainless steel (BS: 3100 316C16F)	Corrosive and special applications
Seal materials	Nitrile	
	Viton	
	Neoprene	
	Ethylene, propylene rubber	
Mounting position	Any orientation	
Ports	Below nominal temperature	Ports A and B connected
	Above nominal temperature	Ports A and C connected
Port connections	Screwed	40 & 50mm (1½" & 2") BSP.PL or NPT
	Flanged	50 - 200mm (2"-8") to most DIN, ANSI, JIS and other standards
Valve sizes (nominal bore)	40, 50, 65, 80, 100, 125, 150 & 200mm (1½", 2", 2½", 3", 4", 5", 6" & 8")	
Control temperatures	See element characteristics table	

Accreditations

PED

1½" to 6" inclusive suitable for Group 1 & Group 2 liquids. 8" Suitable for Group 2 liquids only. (Ensure materials are compatible)

ATEX



II 2 G X



Complies with all relevant EU directives

Temperature settings

A wide selection of temperatures are available. Follow the equipment manufacturers' guidelines for oil systems and for specific operating temperatures of cooling/heating systems.

In general the temperature quoted is the nominal operating temperature in diverting mode on water systems.

For long life AMOT valves should not be operated continuously at temperatures in excess of their maximum continuous rating. If this condition is anticipated then consult AMOT for suitable alternatives.

For mixing and oil circuits the temperature may be 1 to 2°C higher due to flow, viscosity and other system parameters.

Leakholes

Leakholes can be drilled to allow fluid between ports B and C:

1. To allow small flows to cooler during start up which slows down warm up cycle.
2. To allow small flows to maintain some flow through cooler in order to prevent condensation or, in extreme cases, freezing. In applications where additives are not or cannot be used.

In applications where a valve is used as 2-way, with port 'B' blocked and when the circuit is cold and the valve closed, a leakhole is necessary to ensure small flow in order to detect a temperature change in the system.

Manual override option

BR type valves are fitted with a variable manual override which allows a progressive opening of port A to C.

Manual override is often a requirement for marine applications.

In automatic mode the valve will control the temperature automatically, but turning the adjusting nut on top of the operator clockwise will cause the element to move toward its hot (extended) position, regardless of temperature. There is a position indicator on each manual override which shows the element position during manual operation. Each element assembly has its own Manual Override.

Manual Override should only be used in case of an emergency or element failure.

Valve characteristics

Pressure drop

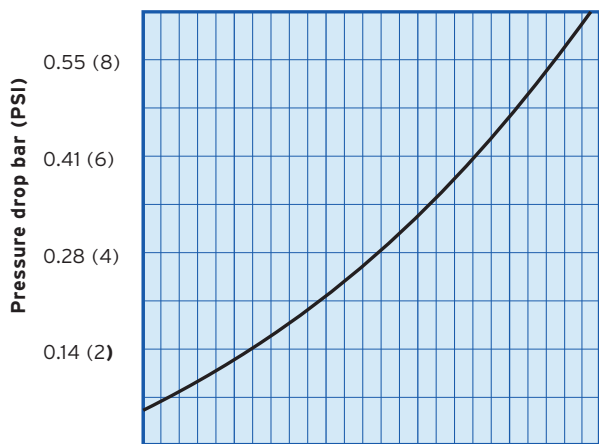

Size	♦	♦	♦	♦	♦	♦
1 1/2	8	12	16	20	24	30
2	10	15	20	25	30	35
2 1/2	19	28	37	46	55	64
3	20	30	40	50	60	70
33	28	41	55	69	84	97
4	40	60	80	100	120	140
5	60	90	120	150	180	210
6	90	135	180	225	270	315
8	135	195	260	320	390	450

Flowrate m³/hr - water

AMOT thermostatic valves are designed to produce minimal pressure drop.

The normal recommendation in sizing AMOT thermostatic valves is to select a pressure drop between 0.14 to 0.5 bar (2 and 7 PSI).

Flow coefficient

AMOT valve flow coefficient (calculated)		
Size	Kv	Cv
1½ B	36	42
2 B	44	51
2½ B	79	81
3 B	87	101
3¾ B	121	140
4 B	176	203
5 B	263	304
6 B	394	456
8 B	571	660

A Cv is the valve's flow coefficient (Kv is the metric coefficient). It is defined as the number of US gallons per minute of room temperature water which will flow through the valve with a pressure drop of 1 PSI across the valve (see table).

Maximum working pressures

Measurements in bar (PSI)

Material	1½B	2B	2BH	2½B	3B	33B	4B	5B	6B	8B
Bronze	10	10	-	10	10	-	10	10	10	10
Cast iron	10	10	22	10	10	6	10	10	10	10
Ductile iron	-	16	-	16	16	-	16	10	10	10
Stainless steel	-	45	-	45	45	-	-	-	-	-
Steel	-	45	-	45	45	-	20	-	-	-
Aluminium	-	10	-	10	10	-	10	10	10	-

Weight

Weights in Kg

Material	1½ BO	2B0, BH, BG	2BF	2BC, BR	2½B0, BR	3B0, BR	33B0, BR	4B0, BR	5B0, BR	6B0, BR	8B0, BR
Bronze	13	13	22	26	29	36	42	68	109	136	315
Cast/ductile iron	11	11	18	18	24	27	35	61	91	123	285
Stainless steel/steel	-	-	-	20	34	36	-	-	-	-	-
Aluminium	-	-	7	-	10	11	14	24	35	48	-

Element characteristics

All temperatures in °C (°F)

Control temperature	Rated range	Max temperature continuous	Application type*			Code
			F.W.	L.O.	S.W.	
13 (55)	8-20 (47-68)	35 (95)	✓	✓	✓	55
14 (57)	10-18 (50-65)	30 (86)	✓	✓	✓	57
24 (75)	20-30 (68-86)	38 (100)	✓	✓	✓	75
32 (90)	27-35 (81-95)	43 (110)	✓	✓	✓	90
35 (95)	29-41 (85-105)	49 (120)	✓	✓	✓	95
38 (100)	34-42 (93-108)	50 (122)	✓	✓	-	100
41 (105)	35-45 (95-113)	55 (131)	✓	✓	✓	105
43 (110)	38-47 (100-117)	56 (133)	✓	✓	✓	110
46 (115)	40-50 (104-122)	61 (142)	✓	✓	-	115
49 (120)	43-54 (110-130)	66 (150)	✓	✓	✓	120
54 (130)	51-60 (124-140)	68 (155)	✓	✓	✓	130
57 (135)	54-63 (129-145)	71 (160)	✓	✓	-	135
60 (140)	57-66 (135-151)	74 (165)	✓	✓	✓	140
63 (145)	60-69 (140-156)	79 (174)	✓	✓	-	145
66 (150)	63-72 (145-161)	82 (180)	✓	✓	✓	150
68 (155)	66-74 (150-165)	85 (185)	✓	✓	✓	155
71 (160)	68-78 (155-173)	88 (190)	✓	✓	✓	160
74 (165)	71-80 (160-175)	88 (190)	✓	✓	-	165
77 (170)	74-83 (165-181)	93 (200)	✓	✓	-	170
79 (175)	77-85 (170-185)	102 (215)	✓	✓	✓	175
82 (180)	79-88 (175-191)	104 (220)	✓	✓	-	180
85 (185)	82-91 (180-196)	106 (223)	✓	✓	-	185
91 (195)	87-98 (188-209)	107 (225)	✓	✓	-	195
96 (205)	93-102 (200-215)	108 (226)	✓	✓	-	205
102 (215)	98-107 (209-225)	115 (239)	✓	✓	-	215
107 (225)	102-113 (216-236)	118 (244)	✓	✓	-	225
110 (230)	104-115 (219-239)	127 (260)	✓	✓	-	230
116 (240)	108-122 (227-252)	132 (270)	✓	✓	-	240

* Element temperature availability: F.W. = Fresh water, L.O. = Oil, S.W. = Saltwater

Valve dimensions

1½ and 2B0/BH/BG 2BF

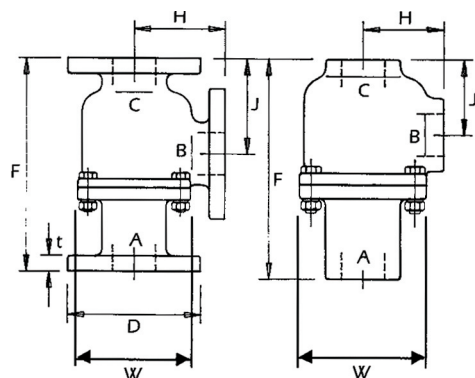

2BC, 2BR and 2½ - 6B0/BR

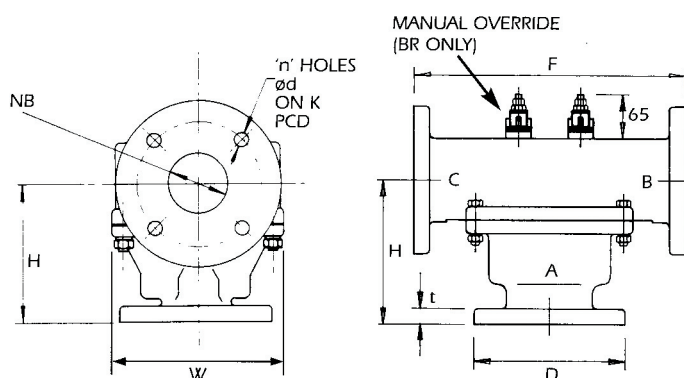

8B0, BR

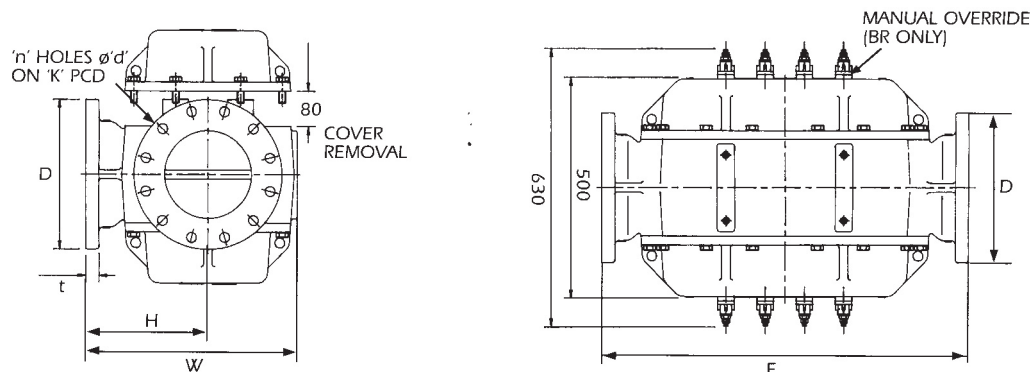

Dimension/ Connection (mm)	1½ B0	2B0/ BH/BG	2BF	2BC/ BR	2½B0/ BR	3B0/ BR	33B0/ BR	4B0/ BR	5B0/ BR	6B0/ BR	8B0/ BR
NB	40	50	50	50	65	80	80	100	125	150	200
F	246	246	270	225	254	267	267	403	489	489	840
H	91	91	113	149	165	171	171	217	241	254	280
J	97	97	121	-	-	-	-	-	-	-	-
D	-	-	165	165	185	200	200	224	254	285	340
W	140	139	139	140	210	210	245	308	349	483	485
t	-	-	20	20	20	22	22	24	26	26	30
K	PN10/16	-	125	125	145	160	160	180	210	240	295
	125/150LB	-	120.6	120.6	139.7	152.6	152.6	190.5	216	240	299
d	PN10/16	-	18	18	18	18	18	18	18	23	22
	125/150LB	-	19	19	19	19	19	19	22.2	23	22
n	PN10/16	-	4	4	4	8	8	8	8	8	8 or 12*
	125/150LB	-	4	4	4	4	4	8	8	8	8

* 8 holes on ND10 flange, 12 holes on ND16 flange

Specification check list

Use the tables below to select the unique specification of your B Valve.

Please select one characteristic from each section. Each characteristic is associated with a code that you will need to state when ordering.

Valve size mm (inches)	Number of elements	Code	✓
40 (1½")	1	1½	
50 (2")	1	2	
65 (2½")	2	2½	
80 (3")	2	3	
80 (3")	3	33	
100 (4")	4	4	
125 (5")	6	5	
150 (6")	9	6	
200 (8")	16	8	

Type	Code	✓
1½" and 2" screwed connections	BO	
2½" to 8" flanged	BO	
Flanged 'T' configuration (2" only)	BC	
Flanged 'F' configuration (2" only)	BF	
Manual override (2" to 8")	BR	
Screwed high pressure (2" only) (cast iron)	BH	
Screwed/screw retained sleeves (2" only) (cast iron)	BG	

Housing material	Code	✓
Aluminium (not 8 and 33)	A	
Bronze (not 33)	B	
Cast iron	C	
Ductile iron	D	
Steel (2", 2½", 3" and 4" only)	S	
316 stainless steel (2", 2½", 3" only)	R	

Port connection	Code	✓
Flanged PN6	A	
Flanged PN10	B	
Flanged PN16	C	
Flanged BS:10 (table D)	D	
Flanged BS:10 (table E)	E	
Flanged ANSI 125lb (cast iron, bronze and ductile only)	F	
Flanged ANSI 150lb (steel and stainless steel only)	J	
Flanged ANSI 300lb (steel and stainless steel only)	H	
Flanged JIS 10k	L	
Flanged JIS 5k	M	
Threaded NPT (1½ and 2 BO only)	T	
Threaded BSP (PL) (1½ and 2 BO only)	U	

Control temperature	Code
See element characteristics table (page vi). Model code located in last column	

Element code	Code	✓
1096X standard	01	
6836S saltwater	05	
2433X standard with manual override	07	
6838S saltwater with manual override	09	

Leakhole sizes mm (inches)	Code	✓
None	0	
13 (½")	A	
6.5 (¼")	B	
9.5 (⅜")	C	
3.2 (⅛")	D	
1.6 (⅙")	E	
2.4 (⅜")	F	
5 (⅜")	G	
8 (⅝")	H	

Leakhole quantity (no. of elements with leak hole, maximum 1 per element)	Code
Refer to valve size table for number of elements	

Special requirements	Code	✓
Standard	AA	
Please contact us for any special requirements		
Notes		

Once you have made your selection, or if you need advice, please call us on:

+44(0)1284 762222

fax +44(0)1284 760256 email info@amot.com

Europe and Africa

AMOT
Western Way
Bury St Edmunds
Suffolk, IP33 3SZ
England

Tel +44 (0) 1284 762222
Fax +44 (0) 1284 760256
Email info@amot.com

Asia and Australasia

AMOT Shanghai
Rm A8-671 Jiahua Business Center
808 Hongqiao Road
Shanghai 200030
China

Tel +86 (0) 21 6447 9708
Fax +86 (0) 21 6447 9718
Email shanghai@amot.com

AMOT Singapore
10 Eunos Road 8 #12-06
Singapore Post Centre
Singapore 408600

Tel +65 6293 4320
Fax +65 6293 3307
Email singapore@amot.com

Americas

AMOT USA
401 1st Street
Richmond
California 94801-2906
USA

Tel +1 (510) 307 8300
Fax +1 (510) 234 9950
Email sales@amotusa.com

AMOT USA
8460 N. Eldridge Parkway
Houston, TX 77041
USA

Tel +1 (281) 970 8268
Fax +1 (281) 671 2160
Email sales@amotusa.com